



Standard Test Method for Comparing Concretes on the Basis of the Bond Developed with Reinforcing Steel¹

This standard is issued under the fixed designation C 234; the number immediately following the designation indicates the year of original adoption or, in the case of revision, the year of last revision. A number in parentheses indicates the year of last reapproval. A superscript epsilon (ϵ) indicates an editorial change since the last revision or reapproval.

1. Scope

1.1 This test method covers comparison of concretes on the basis of the bond developed with reinforcing steel.

1.2 The values stated in inch-pound units are to be regarded as the standard.

1.3 *This standard does not purport to address all of the safety problems, if any, associated with its use. It is the responsibility of the user of this standard to establish appropriate safety and health practices and determine the applicability of regulatory limitations prior to use.*

2. Referenced Documents

2.1 ASTM Standards:

A 370 Test Methods and Definitions for Mechanical Testing of Steel Products²

A 615 Specification for Deformed and Plain Billet-Steel Bars for Concrete Reinforcement³

C 39 Test Method for Compressive Strength of Cylindrical Concrete Specimens⁴

C 138 Test Method for Unit Weight, Yield, and Air Content (Gravimetric) of Concrete⁴

C 143 Test Method for Slump of Hydraulic Cement Concrete⁴

C 173 Test Method for Air Content of Freshly Mixed Concrete by the Volumetric Method⁴

C 192 Practice for Making and Curing Concrete Test Specimens in the Laboratory⁴

C 231 Test Method for Air Content of Freshly Mixed Concrete by the Pressure Method⁴

C 293 Test Method for Flexural Strength of Concrete (Using Simple Beam with Center-Point Loading)⁴

C 511 Specification for Moist Cabinets, Moist Rooms, and Water Storage Tanks Used in the Testing of Hydraulic Cements and Concretes⁵

C 617 Practice for Capping Cylindrical Concrete Specimens⁴

3. Significance and Use

3.1 This test method is not intended either for use in tests in which the principal variable is the size or type of reinforcing bar or for establishing bond values for structural design purposes. This test method is adaptable to use for research purposes by varying the conditions as desired but no attempt to do so has been included in the method.

3.2 This test method may also be used to determine the conformance of a product or a treatment with a requirement relating to its effect on the bond developed between concrete and reinforcing steel.

4. Apparatus

4.1 *Molds for Bond Test Specimens*—Two types of molds will be required: for 6-in. or 150-mm concrete cubes each containing a vertically embedded bar, and for 6 by 6 by 12-in. or 150 by 150 by 300-mm prisms each containing two horizontally embedded bars. The molds preferably shall be made of metal, not less than $\frac{1}{4}$ in. (6 mm) thick. If made of wood, they shall be lined with smooth sheet metal approximately $\frac{1}{8}$ in. (3 mm) thick. The molds shall be watertight. With all-metal molds, watertightness may be accomplished by using grooved joints, or a sealing compound may be applied along the exteriors of the end joints after assembly. Particular care shall be taken to seal the openings where reinforcing bars extend through the molds. The molds shall be designed to hold the bars rigidly in place, including the free ends of projecting bars. The molds shall be constructed for easy removal without disturbance of embedded bars. Suitable molds are shown in Fig. 1.

4.2 *Measuring Apparatus*—Apparatus shall be provided for measuring the movement of the reinforcing bar with respect to the concrete at the loaded end of the bar. Dial gages shall be graduated in 0.001-in. (0.025-mm) units; a range of at least 0.5 in. (13 mm) shall be provided, and a range of 1.0 in. (25 mm) is desirable (Note 1).

NOTE 1—One type of apparatus that has been found satisfactory is shown in Fig. 2. The dial gages are mounted on suitable yokes which are attached to the concrete specimen with setscrews. At the loaded end of the bar, adjustment is accomplished by changing the height of the cap screws on the ends of the split-ring cross bar on which the stems of the dial gages bear. The split-ring cross bar is attached to the reinforcing bar through four screws in the arms of the cross bar which bring the gasket rubber lining into firm contact with the reinforcing bar. The three setscrews as shown

¹ This test method is under the jurisdiction of ASTM Committee C-9 on Concrete and Concrete Aggregates and is the direct responsibility of Subcommittee C09.69 on Miscellaneous Tests for Concrete.

Current edition approved April 15, 1991. Published June 1991. Originally published as C 234 – 49. Last previous edition C 234 – 91.

² *Annual Book of ASTM Standards*, Vol 01.03.

³ *Annual Book of ASTM Standards*, Vol 01.04.

⁴ *Annual Book of ASTM Standards*, Vol 04.02.

⁵ *Annual Book of ASTM Standards*, Vol 04.01.

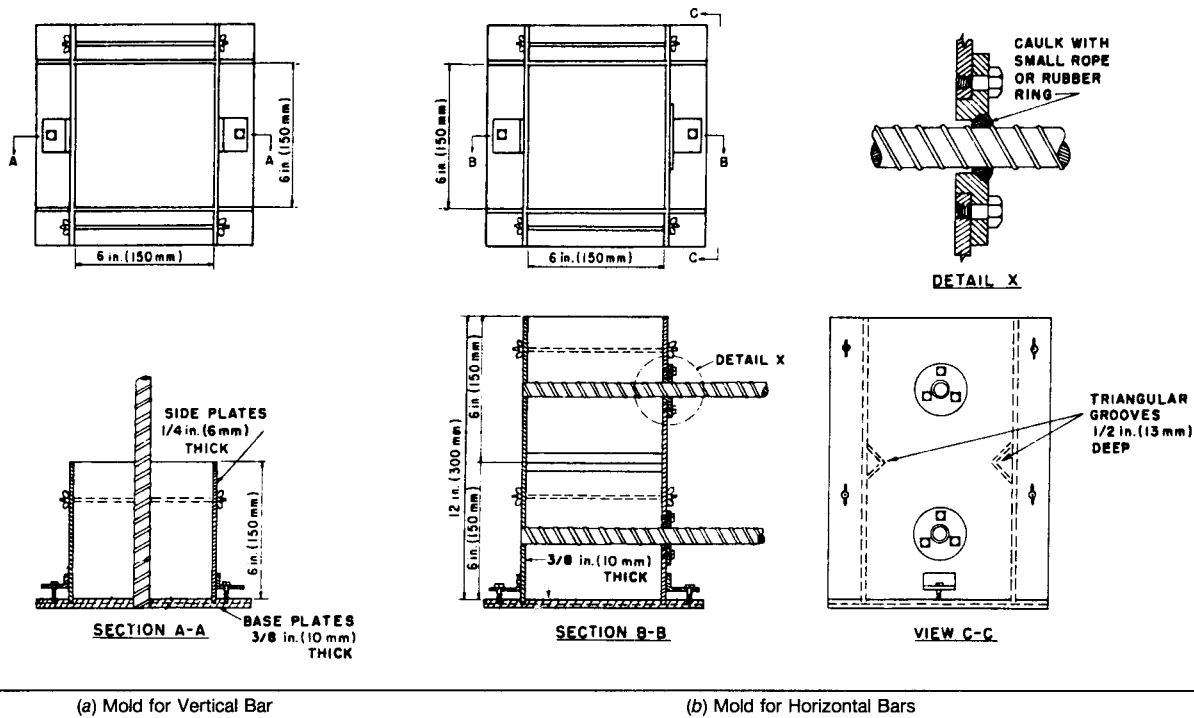

FIG. 1 Molds for Bond Test Specimens

are used to ensure additional cross bar contact. The cross bar is located in a slot machined in the intermediate bearing plate, but is fastened to the reinforcing bar in such a way that no contact is made with the bearing plate during the test.

4.3 *Testing Apparatus*—The capped or bearing surface of the concrete cube shall be supported on a machined steel bearing plate at least 6 in. (150 mm) square and $\frac{3}{4}$ in. (19 mm) thick, with a hole drilled through its center of sufficient diameter to accommodate the reinforcing bar. If a cross bar measuring apparatus similar to that shown in Fig. 2 is used, the bearing plate should be supported on a steel block at least 5 in. (125 mm) in diameter and 3 in. (75 mm) thick. This block should have a central hole to accommodate the reinforcing bar, and in addition, on its top side should have a diametral slot and central hole of dimensions sufficient to accommodate the cross bar. This slotted block shall rest in turn on a spherically seated bearing block at least 5 in. diameter and having a central hole at least $1\frac{1}{2}$ in. (38 mm) in diameter (Fig. 2).

5. Test Specimens

5.1 The test specimens shall be of two types: one containing one reinforcing bar embedded vertically, and the other containing two bars embedded horizontally. Three specimens of each type shall constitute a set of test specimens.

5.2 *Specimens for Vertically Embedded Bar*—These specimens shall consist of concrete cubes, 6 in. or 150 mm on each edge with a single reinforcing bar embedded vertically along a central axis in each specimen. The bar shall project downward from the bottom face of the cube as cast a distance of about $\frac{3}{8}$ in. (10 mm), and shall project upward from the top face whatever distance is necessary to provide sufficient length of bar to extend through the bearing blocks and the support of the testing machine and to provide an adequate length to be gripped for application of load (Fig. 1).

5.3 *Specimens for Horizontally Embedded Bars*—These specimens shall consist of concrete prisms 6 by 6 by 12 in. or 150 by 150 by 300 mm with the longer axes vertical. Two bars shall be embedded in each specimen, perpendicular to the long axis and parallel to and equidistant from the vertical sides of the prism (Fig. 1). In the vertical direction, one bar shall be located with its axis 3 in. (75 mm) from the bottom of the prism, and the other with its axis 9 in. (225 mm) from the bottom. Both bars shall project from the two ends of the specimen distances corresponding to those specified for specimens having a vertically embedded bar. A triangular groove or chamber shall be formed in each of the two opposite sides of the prism parallel to the axes of the bars and at midheight of the prism. These grooves shall be at least $\frac{1}{2}$ in. (13 mm) deep, measured perpendicularly from the surface of the concrete. They are for the purpose of facilitating the breaking of the prism into two test specimens at this weakened plane prior to making the bond tests.

NOTE 2—To obtain the expected maximum effect on bond due to bleeding, settlement, and accumulation of air voids under the bars, the common plane of the two longitudinal ribs on each bar should be in a horizontal plane in the as-cast position.

5.4 *Reinforcing Bars*—The reinforcing bars shall be No. 6 deformed bars conforming to Specification A 615. Care shall be taken that all bars used in a given series of tests are of the same type and have the same size, shape, and pattern of deformations. The lengths of the individual bars shall be such as to meet the requirements of the test specimens.

NOTE 3—In consideration of the size of the test specimens and the consequent limited clearances between the reinforcing bars and the sides of the molds, and for standardization, it is recommended that the size of the coarse aggregate used in the concrete be not greater than 1 in. or 25.0 mm.